



Internationally patented brands and models
Marques et modèles déposés France et International



Fresh drinks
Boissons fraîches

Coffee
Café

Food preparation
Préparation culinaire

**French manufacturer
of commercial electrical equipment
for juice bars, snacking, coffee shops,
hotels, bars, restaurants...**

Fabricant français
de matériel électrique professionnel
pour bars à jus, snacking, coffee shops,
hôtels, bars, restaurants...



60 years of history

60 ans d'histoire

SANTOS, 60 years of history	04
<i>SANTOS, 60 ans d'histoire</i>	
The full juice bar solution	06
<i>La solution complète pour les bars à Jus</i>	
Fruit juices	08
<i>Jus de fruits</i>	
Cocktails & smoothies	11
<i>Cocktails et smoothies</i>	
The full snacking solution	14
<i>La solution complète pour le snacking</i>	
Snacking & catering	16
<i>Restauration et collectivités</i>	
The full coffee shop solution	20
<i>La solution complète pour les coffee shops</i>	
Coffee bars	22
<i>Cafés</i>	
Coffee Shops & supermarkets	24
<i>Coffee shops, boutiques et supermarchés</i>	
Santos world tour	26
<i>Le tour du monde Santos</i>	
Technical data	28
<i>Données techniques</i>	

*Let's
have a drink*

Fresh drinks
Boissons fraîches



6

Inspiration and Precision

Food preparation
Préparation culinaire



14

Passion

Coffee
Café



20



60 YEARS OF HISTORY

Santos, created in 1954 by André Fouquet, manufactures commercial electrical equipment dedicated to cafes, hotels, restaurants, juice bars, coffee shops, snack shops... and offers three different product lines: Fresh Drinks, Food Preparation, Coffee.

Originally, the company was providing professional coffee grinders and cheese graters to small retailers. 60 years after the launch of its first products, Santos continues to grow and the R&D department develops new and innovative products based on our savoir-faire with respect to production of motors. This is one of the reasons why Santos products are reputed for their robustness and reliability.

60 ANS D'HISTOIRE

Santos, entreprise créée en 1954 par André Fouquet, fabrique des équipements professionnels destinés aux cafétérias, hôtels, restaurants, bars à jus, coffee shops, sandwicheries... et propose trois gammes de produits : Boissons Fraîches, Préparation culinaire, Café.

A l'origine, l'entreprise produisait des moulins à café et des râpes à fromage professionnels pour les épicereries de quartier. 60 ans après le lancement de ses premiers produits, Santos poursuit son développement en concevant des produits innovants basés sur son savoir-faire en matière de production et de bobinage des moteurs. C'est certainement l'une des raisons pour laquelle la marque Santos est réputée fiable et robuste.

Innovation Quality

WORLDWIDE NETWORK AND EXPERIENCE

Santos is now represented in more than 130 countries thanks to our network of resellers and importers who contribute to the success of our brand and products on their markets.

We participate in the most important tradeshows all over the world and develop our products to answer the needs of professionals in Europe, Asia, the Middle East, USA...

UNE EXPÉRIENCE ET UN RÉSEAU AU NIVEAU MONDIAL

Notre réseau international de revendeurs et d'importateurs représente la marque et les produits Santos avec succès dans plus de 130 pays.

Nous participons aux principaux salons professionnels dans le monde entier et nous développons nos produits pour répondre aux besoins de nos clients en Europe, en Asie, au Moyen Orient, aux Etats-Unis...



Video

QUALITY, STANDARDS, SERVICE

The thousands of high quality appliances that are produced in our factory are in accordance with the most stringent international regulations (UL, GS, CE, NSF, KETI, GOST, etc...) and can be adapted to all relevant voltages. Besides developing high quality products, our goal is to provide the best possible commercial and after-sales services.

We know that your satisfaction depends on our efficiency.

QUALITÉ, NORMES, SERVICE

Les milliers d'appareils qui sont fabriqués dans notre atelier respectent les normes internationales les plus strictes (UL, GS, CE, NSF, KETI, GOST, etc...) et peuvent être adaptés à tous les voltages locaux.

Notre objectif est de vous fournir un service de qualité en complément de notre gamme de produits. Nous savons que votre satisfaction dépend de notre efficacité.



*Service
expertise
Standards*



MADE IN FRANCE AND SUPPLY CHAIN MANAGEMENT

Santos products are designed and manufactured in our factory, in Lyon (France), and our network of suppliers is local. All our products are hand-made by operators that are responsible of the appliance from the beginning of the production to the final control (100 % tested after assembly). Our solid international experience allows us to be very flexible, we always keep a maximum of items in stock, and we are able to meet tight deadlines.

FABRICATION FRANÇAISE ET RÉSEAU DE SOUS-TRAITANTS LOCAUX

Les appareils Santos sont développés et fabriqués dans notre atelier à Lyon (France) et notre réseau de fournisseurs est local. Tous les produits sont montés par des opérateurs qui sont responsables des appareils du début de leur production jusqu'au contrôle final (100% testés en fin de fabrication). Notre solide expérience internationale nous permet d'être très flexibles et nous sommes en mesure de garantir des délais courts avec un stock complet et diversifié.



INNOVATION, DESIGN AND ECO-CONCEPTION

Year after year, we develop innovative appliances that are the result of our experience of the market since 1954, and we focus more and more on developing eco-friendly products, integrating green technologies, to meet the needs of our customers: first company to launch a brushless motor in a blender, food-zone materials without bisphenol A, packaging in moulded cellulose...

INNOVATION, DESIGN ET ECO-CONCEPTION

Années après années nous développons des appareils innovants qui sont le fruit de notre expérience du marché depuis 1954. Nous attachons toujours plus d'importance au développement de produits respectueux l'environnement, intégrant des technologies vertes, pour répondre aux besoins de nos clients : première entreprise à développer un moteur brushless dans un blender, matériaux en zone alimentaire sans bisphénol A, emballages en cellulose moulée...

*Green
Technology*



Let's have a drink

Fresh drinks
Boissons fraîches



Santos is the specialist of the professional juicing since 1954 and the only manufacturer in the world to provide the full juice bar solution:

citrus juicers + juice extractors + blenders!

Come and test your creativity on our application: My Santos Juice Bar!

Santos est le spécialiste du jus de fruits frais depuis 1954 et le seul fabricant au monde proposant la solution complète pour équiper les bars à jus :

presse-agrumes + centrifugeuses + blenders !

Venez tester votre créativité sur notre application Santos : **My Santos Juice Bar !**



70

Citrus juicer Evolution
**Make a fresh orange,
grapefruit
or lemon juice**

**Presse-agrumes à levier
évolution**

Réalisez des jus d'oranges,
de pamplemousses ou de citrons

*The full
juice bar solution*
*La solution complète
pour les bars à jus*



62

62

Brushless blender

Mix the juice with some ice cubes, frozen fruits or yogurt ice cream

Brushless blender

Mixez vos jus avec quelques glaçons, fruits congelés ou une glace au yaourt



68

68

Juice extractor "Miracle Edition"

Extract juice from various fruits and vegetables (like apples, carrots, pineapples...)

**La centrifugeuse
« Miracle Edition »**

Faites du jus de tous types de fruits et légumes (ex. pommes, carottes, ananas...)

A wide range of citrus juicers

*Une large gamme
de presse-agrumes*



15 l./H



71 C
Chrome
Chromé



Mefra citrus juicer (1 squeezer)
Chromed base (71 C)

Presse-agrumes Mefra (1 ogive)
Socle chromé (71 C)



30 l./H



11
Green
Vert



11 G
Grey
Gris



11 C
Chrome
Chromé

*Since 1954
Depuis 1954*



The genuine citrus juicer
"Classic" citrus juicer (3 squeezers and a cover)
Painted base (11-11 G) or chromed base (11 C)

L'authentique presse-agrumes professionnel
Presse-agrumes « Classic » (3 ogives et un couvercle)
Socle peint (11-11 G) ou socle chromé (11 C)



30 l./H



38
Green
Vert



38 G
Grey
Gris



38 C
Chrome
Chromé



Citrus juicer (3 squeezers and a cover)
Painted base (38-38 G) or chromed base (38 C)

Presse-agrumes (3 ogives et un couvercle)
Socle peint (38-38 G) ou socle chromé (38 C)



40 l./H



52 G
Grey
Gris



52 C
Chrome
Chromé



High output Citrus juicer (3 squeezers)
Painted base (52 G) or chromed base (52 C)
Accepts all kinds of glasses and jugs.

Presse-agrumes gros débit (3 ogives)
Socle peint (52 G) ou socle chromé (52 C)
Accepte tous types de verres et pichets.

- Easy to clean : removable bowl, cone and cup.
- Accepts all kinds of glasses and jugs.
- Squeezer adapted to all kinds of citrus (limes, lemons, oranges, grapefruits).
- Ogive adaptée à tous les agrumes (citrons verts, citrons, oranges, pamplemousses).
- Facile à nettoyer : cuve, ogive et coupelles amovibles.
- Accepte tous types de verres et pichets.



30l./H



10
Grey
Gris



10C
Chrome
Chromé



10C

Automatic citrus juicer with lever (1 squeezer)
Painted (10) or chromed (10C)

Presse-agrumes à levier (1 ogive)
Cuve et socle peints (10) ou chromés (10C)



50l./H



70
Grey
Gris



70C
Chrome
Chromé



70

Lever juicer Evolution 70 (1 squeezer)
Painted (70) or chromed (70C)

Presse-agrumes à levier 70 Evolution (1 ogive)
Cuve et socle peints (70) ou chromés (70C)



32T



100l./H



Stainless Steel
Inox

- **Automatic orange juicer, with stainless steel table (32T)**
- **Automatic orange juicer, without table (32Bac)**

High output automatic orange juicer 100l/h.
Accepts all oranges from 60 to 90mm diameter.
Perfect for juice bars.

- **Presse-oranges automatique avec table inox (32T)**
 - **Presse-oranges automatique, sans table (32 Bac)**
- Grand débit 100 l/h.
Accepte toutes les oranges de 60 à 90 mm de diamètre.
Parfait pour les bars à jus.



32Bac

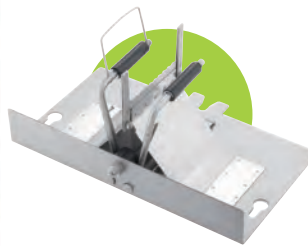

32Bac - 32T, delivered with:

- Water sprayer
- Juice container
- Drip tray

32Bac - 32T, livrés avec :

- Pulvérisateur
- Bac à jus
- Repose-verre

*We have
the juice extractor you need*

*Nous avons la centrifugeuse
qu'il vous faut*



140 L./H



Stainless Steel
Inox

**New generation
centrifugal juice extractor "Miracle edition"**

Perfect filtration + wide feeding chute

**Centrifugeuse nouvelle génération
« Miracle Edition »**

Filtration parfaite + large introduction

The expert's corner

Le coin des spécialistes

68 110

Kit Chefs & Pâtisserie: delivered with 1 basket with 0.8mm holes and 1 wide feed tray

Kit Chefs et pâtisserie : livré avec 1 panier avec trous de 0,8 mm et un plateau verseur



68 J

Juice bar version: delivered with pulp tube

Version bar à jus : livrée avec un tube d'évacuation



Ezy-clean™

**The juice extractors #50
and #68 are equipped
with the Ezy-clean™ system:
Removable bowl and basket.**

Les centrifugeuses N° 50 et N° 68
sont équipées du système Ezy-clean™ :
Panier et cuve amovibles.



100 L./H



58.6 dB



50
Black
Noir



50C
Chrome
Chromé



"Santos juicer"

Painted (50) or chromed base (50C)
Perfect filtration + wide feeding chute

"Santos juicer"

Socle peint (50) ou socle chromé (50 C)
Filtration parfaite + large introduction



100 L./H



64 dB



Stainless Steel
Inox



Centrifugal juice extractor

Perfect filtration

Centrifugeuse

Filtration parfaite



Brushless motor: extensive life expectancy, excellent energy efficiency and low noise level.

Moteur brushless : très grande durée de vie, excellent rendement énergétique et faible niveau sonore.



62

NEW



Black
Noir

Brushless blender

Extremely efficient, silent and easy to use, the brushless blender #62 is the perfect appliance to make smoothies and iced drinks. It crushes all kinds of ice cubes.

Blender brushless

Extrêmement performant, silencieux et simple à utiliser, le blender brushless N° 62 est l'outil parfait pour réaliser les smoothies et boissons glacées. Il broie tous types de glaçons.

Everything for the bar
Tout pour le bar



54
Black
Noir



54R
Red
Rouge



54G
Grey
Gris



54

Drink mixer, electric shaker

Speed variation | 2 bowls - 3 tools

Shaker électrique, drink mixer

Variation de vitesse | 2 bols - 3 agitateurs



33 E
Green
Vert



33GE
Grey
Gris



33 CE
Chrome
Chromé



33GE

Bar blender 33 Evolution 1.25 liter container

Painted base (33E – 33GE) or chromed base (33CE)

→ Also available in standard version without bol detection (33, 33G, 33C)

Mixer de bar 33 Evolution bol 1,25 litre.

Socle peint (33E – 33GE) ou socle chrome (33CE)

→ Disponible également en version standard, sans détection de bol (33, 33G, 33C)



Choose the blender suitable for you
Choisissez le blender adapté à vos besoins !

Everything for the bar... la suite

Tout pour le bar... suite



Beige

Traditional Ice shaver

Broyeur à glaçons traditionnel

Delivered with one adjustable disc for snow ice and crushed ice.

Livré avec un disque réglage pour neige et glace pilée.

It is adapted to intensive use and allows a hands free use thanks to its high capacity tank 1.2 kg.

Adapté à une utilisation intensive et permet un fonctionnement « main libres » grâce à son réservoir à glaçons de 1,2 kg.



Indispensable for your bar
L'incontournable pour votre bar



Grey
Gris

Ice crusher

Two sizes of crushed ice.
Perfect for cocktails (caipirinhas, mojitos...).

Broyeur à glaçons

2 tailles de glace pilée.
Parfait pour les cocktails (caipirinhas, mojitos, ...).



34-1



Stainless Steel
Inox

Cold drink dispenser - 1 bowl x 12 l
Also available with 2 bowls (34-2) or 3 (34-3)
Accepts fruit pieces | High quality compressor

Distributeur de boissons réfrigérées - 1 bac x 12 litres
Disponible avec 2 bacs (34-2) ou 3 (34-3)
Accepte les morceaux de fruits | Compresseur haute qualité

How to make a smoothie ?

Comment faire un smoothie ?



1



Make a fresh orange, grapefruit or lemon juice with the citrus juicer evolution #70.

Réalisez des jus d'oranges, de pamplemousses ou de citrons, à l'aide du presse-agrumes à levier N° 70 évolution.

2



Extract juice from various fruits and vegetables (like apples, carrots, pineapples...) with the juice extractor #68.

Faites du jus de tous types de fruits et légumes (ex. pommes, carottes, ananas...) avec la centrifugeuse N° 68.

3



Then, mix the juice with some ice cubes, frozen fruits or yogurt ice cream in the brushless blender #62.

Puis, mixez le tout avec quelques glaçons, fruits congelés ou une glace au yaourt dans le blender N° 62.

Inspiration & precision

Préparation culinaire
Food preparation



Your partner in food preparation since 1954.

We offer a complete range of products for all needs, from the preparation of your appetizer to the creation of deserts.

Santos est votre partenaire en préparation culinaire depuis 1954.

Nous offrons une gamme complète de produits qui répond à vos besoins, de la préparation de l'entrée jusqu'à la création du dessert.



37

Kitchen blender

Make soups, gazpachos, purées, vegetable foams, creams...

Blender de cuisine

Réalisez des soupes, gazpachos, purées, mousses de légumes, crèmes, glaces...

FOOD

*The full
snacking solution*

*La solution complète
pour le snacking*



48

48

Vegetable slicer

Cut, slice, grate and shred your vegetables and cheese

Coupe-légumes

Coupez, tranchez, râpez, émincez et effilez vos légumes et fromages

12

12

Meat mincer

Prepare ground beef, hamburger steaks, sausages, and pâtés

Hachoir à viande

Préparez vos viandes hachées, saucisses, terrines...

27

27

Planetary mixer

Mix, knead, beat, and whip all kind of preparations

Batteur mélangeur

Mélangez, pétrissez, battez et fouettez toutes sortes de préparations

Unleash your creativity! / Laissez libre cours à votre créativité !

Your partner in the kitchen

Votre partenaire en cuisine



2 I



2 P



4 I



4 P

Choose your bowl
Choisissez votre bol

New blender to mix, liquefy and crush all kinds of hot and cold preparations:

- Powerful motor and new pulse function (18000 rpm)
- New blades for a high quality blending
- Exclusive patented Santosafe® locking system for the bowl and the cover

Nouveau blender pour mixer, émulsionner et broyer toutes sortes de préparations chaudes ou froides :

- Moteur puissant et nouvelle fonction pulse (18 000 tr / min)
- Nouveaux couteaux pour une qualité de mixage optimale
- Système de sécurité exclusif Santosafe® verrouillant le bol et le couvercle



Grey
Gris

Santosafe kitchen blender

Painted base (37)

Blender de cuisine Santosafe

Socle peint (37)



18



Beige

10 liter dough mixer (kneader)

Stainless steel bowl

The ideal dough mixer to make 4kg of hard dough

Pétrin mélangeur 10 litres

Cuve inox

Le pétrin idéal pour réaliser 4 kg de pâte dure.



27



Beige

10 liter planetary mixer

3 planetary tools - 8 speeds

Batteur mélangeur 10 litres

3 accessoires planétaires - 8 vitesses



**Your partner
in food preparation since 1954**
A complete range of products for all needs:
catering, fast-food, institutions, snack shops,
creative cooking, pastries...
Unleash your creativity

**Votre partenaire
en préparation culinaire depuis 1954**
Une gamme complète de produits pour répondre
à tous les besoins : restauration rapide et traditionnelle,
collectivités, traiteurs, cuisine créative, pâtisserie...
Laissez libre cours à votre créativité



02



Beige

Grater (1 standard disc Ø 3 mm)

Râpe (1 disque standard Ø 3 mm)



Range of discs – Grater #02

A unique range of discs to grate all kinds of cheese,
dried fruits, chocolate, coconut, peanuts...

Gamme de disques – Râpe N° 02

Une gamme unique de disques pour râper tous types de fromages,
fruits secs, chocolats, noix de coco, cacahuètes...

*The best value for money
of the market!*

*Le meilleur rapport
qualité / prix du marché !*



48



Grey
Gris

Vegetable slicer with high output

Delivered with 3 standard discs (Slicer T3, Grater R3, Shredder E8).

A wide range of discs available on demand.

Coupe légumes à gros débit

Livré avec 3 disques standard (Trancheur T3, Râpe R3, Effileur E8)

Une large gamme de disques disponibles sur demande

TO4



R3

TD4



E4

T3



RP

RR



E8

Range of discs - Vegetable slicer # 48

A complete range of discs to slice, cut, grate and shred.

Gamme de disques - Coupe-légumes n°48

Une gamme complète de disques pour trancher, couper, râper et effiler.

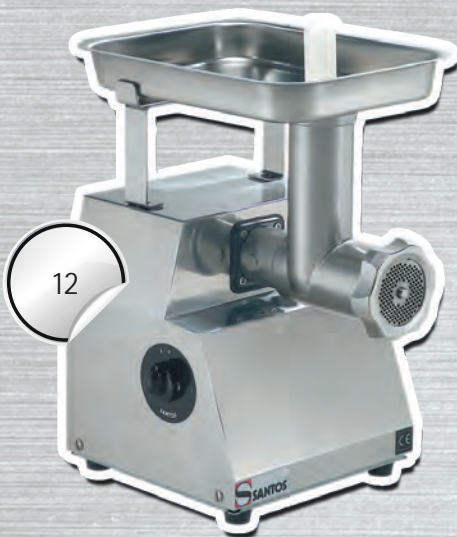

12



12-12
Stainless Steel
Inox



12-12 R
Red
Rouge

Stainless steel meat mincer body. Delivered with 3 plates Ø 70mm

Hachoir à viande corps inox. Livré avec 3 grilles Ø 70 mm



Option

Set of 3 sausages cones in option

(to use with a special plate
with Ø20mm holes)

**Jeu de 3 cornets à saucisse
en option**

(à adapter sur une grille spéciale
avec trous de Ø 20 mm)



*“Environmentally
friendly”*
Écologique



61



Stainless Steel
Inox



Recycling waste compactor

Small, useful and powerful to solve your everyday waste problems.

Compacteur à déchets recyclables

Petit, pratique et puissant pour résoudre vos problèmes de déchets quotidiens.

Passion

Coffee
Café



Coffee grinders: Santos know-how

- Since 1954, we manufacture our own grinding discs for better results
- Santos is the leader in “Silent” coffee grinders
- Constant and fine grinding, constant portion dispensed
- No “burn coffee” effect while grinding, no electrostatic coffee phenomenon
- Easy to adjust (grinding and dosing) and to maintain (changing the grinding discs is very easy)

Moulins à café : le savoir-faire Santos

- Depuis 1954, Santos conçoit et produit ses propres meules de broyage pour un résultat optimal
- Santos est le spécialiste du moulin à café Silence
- Qualité et finesse de la mouture, régularité de la dose distribuée
- Dissipation thermique évitant les moutures chauffées, pas de phénomène de café électrostatique
- Réglages faciles (mouture et dose distribuée) et changement simple des meules

Chocolat chaud 3.50
Chocolat Viennois 4.10



63

SANTOS

63

Coffee shop grinder
Make large quantities
of fresh ground coffee

Moulin à café coffee shop
Faites de larges quantités de sacs
de café fraîchement moulu

é de la semaine	2.20
presso	2.00
presso Macchiato	2.60
presso Con Panna	2.60
è Latte	3.00
uccino	3.10
mel Macchiato	4.30
è Moka	3.10
è Moka blanc	3.70



62

Brushless blender
Make milkshakes, iced coffee frappe, iced tea...

Blender brushless
Réalisez des milkshakes, cafés frappés, mocha glacés, thés frappés...

54

Drink mixer
Prepare iced coffee frappe and any kind of creamy and frozen beverages

Shaker électrique
Préparez des cafés frappés et toutes sortes de boissons émulsionnées et glacées

55

Espresso coffee grinder
Offer fresh ground coffee for your espressos

Moulin à café espresso automatique
Offrez un café moulu ultra frais pour vos espressos

Espresso coffee grinders

Moulins à café espresso



06A



8 Kg/H



Brown
Brun

Espresso coffee grinder
Moulin à café bar



40 AN
Black
Noir



40 AG
Grey
Gris



40 A
Brown
Brun



40AN

Silent espresso coffee grinder

Available with mobile coffee tamper (40APPM)

Moulin à café bar silencieux

Disponible avec presse-poudre mobile (40APPM)



8 Kg/H



63 dB



60N



16 Kg/H



63 dB



Black
Noir

Espresso coffee grinder with removable dispenser

Moulin à café espresso à doseur amovible



Removable dispenser, adaptable on tabletop coffee dispenser (56/57)

Doseur amovible, adaptable sur socle (56/57)

Automatic / Automatique

55BF



25 Kg/H



63 dB

Automatic silent espresso coffee grinder
Grey Front Panel (55) or Black Front Panel (55 BF)

Moulin à café espresso silencieux "automatic"
Façade grise (55) ou façade noire (55 BF)

*An extended offer...
Une offre élargie...*



55
Grey
Gris



55 BF
Black
Noir



55 BM
Skinny grey
Gris émerisé



55 BAR
Black
Noir

The "Automatic" silent espresso coffee grinder #55 dispenses the precise dose of coffee for 1 or 2 espressos directly into the filter holder, which gives you the warranty of a fresh ground coffee.

Le moulin à café espresso silencieux automatique N° 55 distribue directement dans le porte-filtre la dose de café nécessaire pour 1 ou 2 espressos, ce qui garantit un café moulu ultra frais.



56N



Black
Noir

Tabletop precision coffee dispenser
Available in wall-mounted version (57)

Doseur espresso de précision sur socle
Disponible en version murale (57)



75



Black
Noir

Espresso coffee machine (1 group)
"Santos Espresso"

Machine à café espresso (1 groupe)
"Santos Espresso"

Coffee shop grinders

Moulins à café
boutiques
et coffee shops



Brown
Brun

Coffee grinder with drawer

→ Available with bag holder (01 PS),
or in pepper grinder version with drawer (01 P),
or in poppy grinder version (01 PV)

Moulin à café tiroir

→ Disponible avec pince-sac (01 PS), ou en moulin
à poivre - tiroir (01 P), ou en moulin à pavot (01 PV)



04 N
Black
Noir



04
Brown
Brun



Coffee grinder with bag holder
Moulin à café - Pince à sac



Stainless Steel
Inox

Silent portion coffee grinder with timer

Brew baskets or drawer adaptable
(delivered with drawer)

Moulin à café silencieux avec minuterie

Porte-filtres ou tiroir adaptables (livré avec tiroir)



*A Santos product
for every need,
everywhere
in the world*

*Un produit Santos
pour chaque besoin
partout dans le monde*

Santos World Tour

Le tour du Monde Santos

60 years of experience all around the world

*Une expérience enrichie
depuis 60 ans à travers le monde*



*France
Espresso*

55



*Hong Kong
Carrot juice*

68



*Australia
Coffee*

63

An exploded view diagram of a kitchen sink assembly. The components are arranged vertically, showing the top rim, the main sink basin, the drain assembly with a strainer, and the mounting hardware. The diagram is rendered in a light gray line-art style.

Technical data

Données techniques



Fresh drinks

Boissons fraîches

Reference Référence	Available voltages Voltages disponibles	Power Puissance (W)	Speed at 50Hz Vitesse à 50Hz (rpm; tr/min)	Specifications Spécifications	Standards Normes										Colors Couleurs				Dimensions (DxWxH) inches (P x L x H) pouces	Net weight (lbs) Poids net (lbs)
					CE	GS	UL/ETL	NSF	KC	Stainless Steel Inox	Chrome Chromé	Black Noir	Grey Gris	Green Vert	Red Rouge	White Blanc				
Citrus juicers Presse agrumes																				
71C	Mefra citrus juicer - chromed base (1 squeezer) Presse agrumes Mefra socle chromé (1 ogive)	71C	220-240V-50/60Hz	40	80	15 l/h	●											9,3 x 6,7 x 12,2	7,7	
		71CV1	100-120V-50/60Hz	40																
11	"Classic" citrus juicer (3 squeezers) Presse agrumes « Classic » (3 ogives)	11 / 11G / 11C	220-240V-50/60Hz	130	1500	30 l/h	●	●										11,8 x 9 x 13,8	11	
		11V1 / 11GV1 / 11CV1	100-120V-50/60Hz	155																
38	Citrus juicer (3 squeezers) Presse agrumes (3 ogives)	38 / 38G / 38C	220-240V-50/60Hz	130	1500	30 l/h	●											11,9 x 6,7 x 13,8	11	
		38V1 / 38GV1 / 38CV1	100-120V-50/60Hz	155																
52	Citrus juicer - painted base (3 squeezers) Presse agrumes - socle peint (3 ogives)	52G / 52C	220-240V-50/60Hz	230	1500	40 l/h	●	▲										8 x 12 x 19,3	20,9	
		52GV1 / 52CV1	100-120V-50/60Hz	260																
10	Automatic citrus juicer with lever Presse agrumes à levier	10 / 10C	220-240V-50/60Hz	230	1500	30 l/h	●	●										11,8 x 7,9 x 15	20,9	
		10V1 / 10CV1	100-120V-50/60Hz	260																
70	Lever Juicer Evolution 70 (1 squeezer) Presse agrumes à levier 70 Evolution (1 ogive)	70 / 70C	220-240V-50/60Hz	300	1500	50 l/h	●	●										15,7 x 9,4 x 19,3	29,8	
		70V1 / 70CV1	100-120V-50/60Hz	350																
32 Bac	Automatic orange juicer with drip tray Presse oranges automatique avec repose verre	32Bac	220-240V-50Hz	600	1500	100 l/h	●											24,4 x 16,1 x 40,2	144,4	
		32BacV4	220-240V-60Hz	600																
		32BacV1	100-120V-50/60Hz	650																
32T	Automatic orange juicer, with stainless steel table Presse-oranges automatique avec table inox	32T	220-240V-50Hz	600	1500	100 l/h	●											30,3 x 16,1 x 71,3	190,7	
		32TV4	220-240V-60Hz	600																
		32TV1	100-120V-50/60Hz	650																
Juice extractors Centrifugeuses																				
68	New generation centrifugal juice extractor "Miracle edition" Centrifugeuse nouvelle génération « Miracle Edition »	68	220-240V-50/60Hz	1300	3000	140 l/h	●	▲										22,1 x 13 x 23,9	55,1	
		68V1	100-120V-50/60Hz	1300																
50	"Santos Juicer" (Ezy-Clean™ System) « Santos Juicer » (Système Ezy-Clean™)	50 / 50C	220-240V-50/60Hz	800	3000	100 l/h	●	▲										18,5 x 10,2 x 17,7	30,9	
		50V1 / 50CV1	100-120V-50/60Hz	800																
28	Centrifugal juice extractor Centrifugeuse	28	220-240V-50/60Hz	1300	3000	100 l/h	●	●										18,9 x 12,6 x 22,4	52,9	
		28V1	100-120V-50/60Hz																	
Blenders, Drink mixers Mixeurs, Shakers électriques																				
62	Brushless blender Blender Brushless	62	220-240V-50/60Hz	1500	15000	2,4 l	●	●										9,7 x 7,9 x 17,3	20,9	
		62V1	100-120V-50/60Hz	1500																
54	Drink mixer, electric shaker Shaker électrique, drink mixer	54 / 54R / 54G	220-240V-50/60Hz	230	8000 - 16000	0,675 l	●	▲										7,3 x 7,2 x 20,9	13,2	
		54V1 / 54RV1 / 54GV1	100-120V-50/60Hz	230																
33	Bar blender Mixeur de bar	33 / 33G / 33C	220-240V-50/60Hz	600	13000 - 16000	1,25 l	●											7 x 7 x 16,5	6,6	
		33V1 / 33GV1 / 33CV1	100-120V-50/60Hz	600																
33E	Bar blender Evolution – bowl detection Mixeur de bar Evolution – détection de bol	33E / 33GE / 33CE	220-240V-50/60Hz	600	13000 - 16000	1,25 l	●											7 x 7 x 16,5	6,6	
		33EV1/33GEV1/33CEV1	100-120V-50/60Hz	600																
Ice crushers Broyeurs à glaçons																				
9	Ice shaver Broyeur à glaçons	09	220-240V-50Hz	600	1500	1,6 kg/min	●											16,5 x 9,8 x 13,8	32	
		09V4	220-240V-60Hz	600																
		09V1	100-120V-50/60Hz	650																
53	Ice crusher Broyeur à glaçons	53	220-240V-50/60Hz	130	73	2,4 kg/min	●											13,9 x 9,3 x 18,7	22	
		53V1	100-120V-50/60Hz																	
Cold drink dispensers Distributeurs de boissons																				
34-1	Cold drink dispenser (1 bowl x 12l) Distributeur de boissons réfrigérées (1 bac x 12 l)	34-1	220-240V-50Hz	160	-	12 l	●											16,9 x 7,5 x 21,5	34,2	
		34-1V4	220-240V-60Hz																	
		34-1V1	100-120V-50/60Hz																	
34-2	Cold drink dispenser (2 bowls x 12l) Distributeur de boissons réfrigérées (2 bacs x 12 l)	34-2	220-240V-50Hz	260	-	2 x 12 l	●											16,9 x 15 x 21,5	51,8	
		34-2V4	220-240V-60Hz																	
		34-2V1	100-120V-50/60Hz																	
34-3	Cold drink dispenser (3 bowls x 12l) Distributeur de boissons réfrigérées (3 bacs x 12 l)	34-3	220-240V-50Hz	330	-	3 x 12 l	●											16,9 x 22,4 x 21,5	67,2	
		34-3V4	220-240V-60Hz																	
		34-3V1	100-120V-50/60Hz																	

Standards | Normes :
 ● Approved | Approuvé
 ▲ Pending | En cours



Food preparation

Préparation culinaire

	Référence	Available voltages Voltage: disponibles	Power Puissance (W)	Speed at 50Hz Vitesse à 50Hz (rpm; tr/min)	Specifications Spécifications	Standards Normes								Colors Couleurs				Dimensions (D x W x H) inches (P x L x H) pouces	Net weight (lbs) Poids net (lbs)
						CE	GS	UL	NSF	Stainless Steel Inox	Chrome Chromé	Grey Gris	Beige	White Blanc	Red Rouge				
Kitchen blender Blender de cuisine																			
37	Santosafe® kitchen blender painted base only (without any bowl) Blender de cuisine Santosafe® socle peint - Base seule sans bol	37	220-240V 50/60Hz	1200	0-18000	-	●										11,9 x 8,7 x 22,3	19,8	
374P	Santosafe® kitchen blender painted base 4 liter (1 gallon) transparent container Blender de cuisine Santosafe® socle peint Bol 4 litres Polymère (sans bisphénol A)	374P	220-240V 50/60Hz	1200	0-18000	4L	●										11,9 x 8,7 x 22,3	24,3	
374I	Santosafe® kitchen blender painted base 4 liter (1 gallon) stainless steel container Blender de cuisine Santosafe® socle peint Bol 4 litres Inox	374I	220-240V 50/60Hz	1200	0-18000	4L	●										11,9 x 8,7 x 22,3	24,3	
372P	Santosafe® kitchen blender painted base 2 liter (1/2 gallon) transparent container Blender de cuisine Santosafe® socle peint Bol 2 litres Polymère (sans bisphénol A)	372P	220-240V 50/60Hz	1200	0-18000	2L	●										11,9 x 8,7 x 22,3	24,3	
372I	Santosafe® kitchen blender painted base 2 liter (1/2 gallon) stainless steel container Blender de cuisine Santosafe® socle peint Bol 2 litres Inox	372I	220-240V 50/60Hz	1200	0-18000	2L	●										11,9 x 8,7 x 22,3	24,3	
10 liter dough mixer and planetary mixer Pétrin et batteur mélangeur 10 litres																			
18	10 liter dough mixer (kneader) stainless steel bowl Pétrin mélangeur 10 litres - cuve inox	18	220-240V-50/60Hz	600	1500	4 kg	●										19,7 x 13,8 x 16,5	39,7	
		18V1	100-120V-50/60Hz	650			●												
27	10 liter mixer with 3 planetary tools 8 speeds Batteur mélangeur 10 litres avec 3 accessoires planétaires - 8 vitesses	27	220-240V-50/60Hz	600	1500	5 kg	●										20,9 x 14,2 x 22,8	68,3	
		27V3	Tri 380V-50Hz	510			●												
		27V1	100-120V-50/60Hz	650			●												
Grater Râpe																			
02	Grater (1 standard disc) Râpe (1 disque standard)	02	220-240V-50Hz	600	1500	50 kg/h	●										16,5 x 9,8 x 13,8	32	
		02V4	220-240V-60Hz	600			●												
		02V1	100-120V-50/60Hz	650			●												
Vegetable Cutter Coupe légumes																			
48	Vegetable slicer Coupe légumes	48	220-240V-50/60Hz	390	1000	300 kg/h	●										16,5 x 9,8 x 22,8	37,5	
		48V1	100-120V-50/60Hz	450			●												
Meat mincer Hachoir à viande																			
12-12	Meat mincer - stainless steel mincer body Hachoir à viande - corps inox	12-12 / 12-12R	220-240V-50/60Hz	600	1500	160 kg/h	●										16,5 x 10,2 x 16,5	41,9	
		12-12V1 / 12-12RV1	100-120V-50/60Hz	650			●												
Recycling waste compactor Compacteur à déchets recyclables																			
61	Recycling waste compactor Compacteur à déchets recyclables	61	220-240V-50/60Hz	280	-	1.3 t	●										26 x 18,9 x 33,5	286,6	
		61V1	100-120V-50/60Hz	260			●												

Standards | Normes :

- Approved | Approuvé
- ▲ Pending | En cours



Coffee
Café

Reference Référence	Available voltages Voltage disponibles	Power Puissance (W)	Speed at 50HZ Vitesse à 50HZ (rpm;tr/min)	Specifications Spécifications	Standards Normes										Colors Couleurs				Dimensions (DxWxH) inches (P x L x H) pouces	Net weight (lbs) Poids net (lbs)
					CE	GS	UL	NSF	KC	Stainless Steel Inox	Chrome Chromé	Brown Brun	Black Noir	Grey Gris	Shiny Grey Gris émaillé					

Espresso coffee grinders | Moulins à café bar (espresso)

06	Espresso coffee grinder Moulin à café bar	06	220-240V-50Hz	360	1500	8 kg/h	●												13,8 x 9 x 22,4	22
		06V4	220-240V-60Hz	360																
		06V1	100-120V-50/60Hz	310				●												
06A	Automatic espresso coffee grinder Moulin à café bar doseur automatique	06A	220-240V-50Hz	360	1500	8 kg/h	●												13,8 x 9 x 22,4	22
		06AV4	220-240V-60Hz	360																
		06AV1	100-120V-50/60Hz	310				●												
40A	Autom. silent espresso coffee grinder Moulin à café bar doseur auto. silencieux	40A / 40AN / 40AG	220-240V-50Hz	360	1500	8 kg/h	●												15,4 x 7,5 x 22,8	30,9
		40AV4 / 40ANV4 / 40AGV4	220-240V-60Hz	360																
		40AV1 / 40ANV1 / 40AGV1	100-120V-50/60Hz	310				●												
55	Automatic espresso coffee grinder Moulin à café espresso automatique	55 / 55BF	220-240V-50/60Hz	1100	2800	25 kg/h	●	▲											15,6 x 7,8 x 22,7	33
		55V1 / BFV1	100-120V-50/60Hz	800																
55BM 55BAR	Automatic espresso coffee grinder Blue Mountain and Black Moulin à café espresso automatique Blue Mountain et Black	55BM/55BAR	220-240V-50/60Hz	1100	2800	25 kg/h	●	▲											15,6 x 7,8 x 22,7	33
		55BMV1 / 55BARV1	100-120V-50/60Hz	800																
60N	Silent coffee grinder with removable coffee dispenser Moulin à café espresso à doseur amovible	60N	220-240V-50/60Hz	600	2800	16 kg/h	●												15,6 x 7,8 x 22,8	34,2
		60NV1	100-120V-50/60Hz	800																

Precision coffee dispenser | Doseur Espresso de précision

56N	Tabletop precision coffee dispenser Doseur espresso de précision sur socle	-	-	-	-	-	-	●											11 x 6,6 x 15,6	11
-----	---	---	---	---	---	---	---	---	--	--	--	--	--	--	--	--	--	--	-----------------	----

Espresso coffee machine | Machine à café espresso

75	Espresso coffee machine (1 group) "Santos espresso" Machine à café espresso (1 groupe) « Santos espresso »	75	220-240V-50/60Hz	1240	-	16 bar	●												12,6 x 10,4 x 15,7	38,6
		75V1	100-120V-50/60Hz	1240																

Coffee shop grinders | Moulins à café boutiques et coffee shops

01	Coffee grinder with drawer or bag holder Moulin à café - tiroir ou pince-sac	01	220-240V-50Hz	600	1500	14 kg/h	●												12,6 x 9,8 x 21,7	30,9
		01V4	220-240V-60Hz	600																
		01V1	100-120V-50/60Hz	650																
01P	Pepper (spices) grinder with drawer Moulin à poivre (épices) - tiroir	01P	220-240V-50Hz	600	1500	14 kg/h	●												12,6 x 9,8 x 21,7	30,9
		01PV4	220-240V-60Hz	600																
		01PV1	100-120V-50/60Hz	650																
04	Coffee grinder with bag holder Moulin à café - pince-sac	04	220-240V-50Hz	600	1500	14 kg/h	●												12,6 x 8,7 x 27,6	39,7
		04V4	220-240V-60Hz	600																
		04V1	100-120V-50/60Hz	650																
42	Silent portion coffee grinder Moulin à café doseur filtre silencieux	42	220-240V-50Hz	600	1500	14 kg/h	●												13,2 x 7,5 x 21,9	41,9
		42V4	220-240V-60Hz	600																
		42V1	100-120V-50/60Hz	650																
43	Silent shop coffee grinder with bag holder Moulin à café boutique silencieux - pince-sac	43	220-240V-50Hz	600	1500	14 kg/h	●												13,2 x 7,5 x 27,1	44
		43V4	220-240V-60Hz	600																
		43V1	100-120V-50/60Hz	650																
63	Coffee Shop Grinder Moulin à café Coffee Shop	63	220-240V-50Hz	1500	1500	120 kg/h	●	▲											13 x 11 x 26,7	88,2
		63V4	220-240V-60Hz	1500																
		63V1	100-120V-50/60Hz	1500				▲												

Standards | Normes :

- Approved | Approuvé
- ▲ Pending | En cours



MIRACLE EXCLUSIVES
36 Kenosia Avenue
DANBURY, CT 06810
USA



Phone: 1-800-645-6360
E-mail: info@miracleexclusives.com
Website: www.santosjuicers.com